

Hand type DEM-M1

Demagnetization

- For manual handling
- Heavy-duty construction with double demagnetizing cycle for long-lasting durability
- Coils incorporated inside cast aluminium housing
- Safety handle
- ON/OFF switch

Included with purchase:

3-meter-long cable

Magnetic field height: 50 mm

Voltage: 230 VAC

Duty cycle: 50%

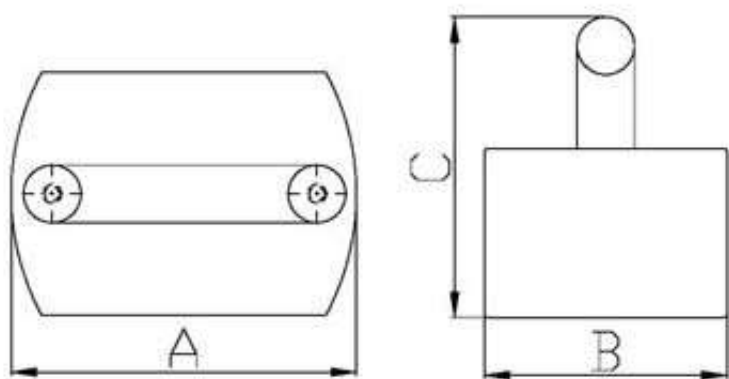

D= Puissance – Power – Leistung

CODE	Weight Kg	A	B	C
16.03.M1	5,8	200	145	150